

75 P

Excavator



JOHN DEERE





BUILT FOR WHAT YOU DO — AND THEN SOME

When we designed the 75 P-Tier, we started with a larger, brand-new cab to keep operators comfortable. Then we combined the agility and adaptability of our smaller compact models with the productive performance and versatile capabilities of the largest excavators in our wide-ranging lineup. And we amped up engine horsepower by 17 percent compared to the previous model, added a turbocharger for improved performance at elevated altitudes, increased dig forces and hydraulic pressure, and optimized machine stability by 10 percent. With customer-inspired features like these, plus some pretty big options, this enhanced excavator can be just the right-size solution for your toughest tasks.

75 P-TIER EXCAVATOR

FEATURES

Transit authority

Reduced-tail-swing configuration enhances machine flexibility, enabling the 75 P-Tier to maneuver nimbly and work efficiently on tight and congested jobsites. Plus this go-to taskmaster transports easily, making it ideal for “dig-and-go” projects.

Modes of operation

Engine performance and hydraulic flow are optimally balanced for predictable operation. Two productivity modes allow you to choose the digging style that fits the job: **Power** delivers a balance of speed and fuel economy for normal operation, while **Economy** reduces engine speed and helps save fuel.

In control and comfortable

Ergonomically correct short-throw pilot joysticks enable smooth, precise fingertip control. Handy new swing-boom functionality in the joystick eliminates a hard-to-reach floor pedal and clears space to move your legs.

At home in the cab

All-new operator station that's more spacious than previous models features a completely new adjustable and heated air-suspension seat with armrests, comfortable air-conditioning system, and ample entry-way and legroom. Wide expanse of front and side glass, narrow front cab posts, large tinted overhead window, and numerous mirrors enable outstanding visibility. Isolated cab mounts help reduce noise and vibration.

Stay connected

New 8-inch multi-language LCD monitor equipped with Bluetooth® connectivity to phone calls and music provides intuitive access to a wealth of information and functions. Just turn and tap the rotary dial to select work mode, access operating info, check service intervals, source diagnostic codes, adjust cab temperature, and tune the radio. Handy USB port and cellphone holder make it easy to stay in touch.

Bring your work into focus

Standard LED lighting illuminates dusty and before-daylight or after-dark jobsites. Integrated into the all-new, high-resolution main monitor for optimal image quality, the standard right rear left camera system with additional LED surround lighting work together to supplement 270-degree visibility of the area around the machine, even in low-light conditions.



REDUCED-TAIL-SWING
DESIGN PROVIDES FLEXIBLE
PERFORMANCE IN TIGHT SPACES
COMPARED TO CONVENTIONAL TAIL-SWING MACHINES

Bank on these blades

Standard blade is ideal for cleanup and backfilling. It provides extra lift capacity and stability when running hydraulic hammers and other heavy-duty attachments. Optional new angle blade with float redefines earthmoving and grading.

Rugged resistance

Large idlers, rollers, and strutted links enable the undercarriage to withstand and command. Thick-plate single-sheet mainframe, box-section track frames, double-seal swing bearing, and new boom-cylinder guard deliver rock-solid durability. All structures and components are built to resist stress.

It's all right here

Large hinged doors provide easy wide-open access to service items including cooler and condenser cleanout. Remote oil-filter and filter-bank access, remote swing-bearing grease bank, generous fuel tank, and 500- and 5,000-hour engine and hydraulic oil-service intervals minimize downtime for routine maintenance. Fluid-level sight gauges are conveniently located and can be checked at a glance.

Auxiliary forces

Factory-installed standard auxiliary hydraulics with proportional control boost jobsite productivity and attachment capability. High-pressure, high-flow auxiliary hydraulic packages power the addition of a hydraulic hammer or a wide range of over 100 John Deere attachments.

Where the rubber meets the road

Optional rubber track pads let the 75 P-Tier set up and work on paved surfaces and even cross curbs without doing damage.





DEERE

75 P-TIER EXCAVATOR



WIDE-OPEN ACCESS EASES ROUTINE MAINTENANCE

Work your way

Undercarriage options include sealed and lubricated chain with rubber pads or steel semi-grousers from 18- to 24-inches wide. Numerous bucket options let you spec the excavator for the way you work.

Connected machines

The 75 P-Tier Excavator arrives JDLink™ ready and connectivity capable. Via a simple dealer-installed hardware kit, you can analyze critical machine data, track utilization, review diagnostic alerts, and more from **the John Deere Operations Center™**. The Operations Center also enables **John Deere Connected Support™**, which uses data from thousands of connected machines to proactively address issues before they arise. Once you opt in, your dealer can remotely monitor machine health, diagnose problems, and even update machine software without a trip to the jobsite.*

*Availability varies by region and product. Options not available in every country.



While general information, pictures, and descriptions are provided, some illustrations and text may include product options and accessories NOT AVAILABLE in all regions, and in some countries products and accessories may require modifications or additions to ensure compliance with the local regulations of those countries.

Engine		75 P-TIER	
Manufacturer and Model	Yanmar 4TNV98CT		
Non-Road Emission Standard	EPA Final Tier 4/EU Stage IV		
Net Power (ISO 14396)	50.4 kW (67.6 hp) at 2,000 rpm		
Cylinders	4		
Displacement	3.3 L (202 cu. in.)		
Aspiration	Turbocharger		
Off-Level Capacity	70% (35 deg.)		
Cooling		Variable-speed fan; viscous clutch	
Powertrain		2-speed propel with automatic shift	
Maximum Travel Speed			
Low	3.1 km/h (1.9 mph)		
High	5.0 km/h (3.1 mph)		
Drawbar Pull	7240 kgf (15,961 lb.)		
Hydraulics		Open center, load sensing	
Main Pumps		3 variable-displacement axial-piston pumps	
Maximum Pump Flow	2 x 72 + 56 L/m (2 x 19 + 15 gpm)		
Pilot Pump		1 gear	
Maximum Rated Flow	20 L/m (5.3 gpm)		
System Relief Pressure	4300 kPa (624 psi)		
System Operating Pressure			
Implement Circuits	28 000 kPa (4061 psi)		
Travel Circuits	31 600 kPa (4,583 psi)		
Swing Circuits	26 100 kPa (3,785 psi)		
Controls		Pilot levers, short stroke, low effort; hydraulic pilot controls with shutoff lever	
Cylinders		Heat-treated, chrome-plated, polished cylinder rods; hardened steel (replaceable bushings) pivot pins	
	<i>Bore</i>	<i>Rod Diameter</i>	<i>Stroke</i>
Boom (1)	115 mm (4.5 in.)	70 mm (2.8 in.)	885 mm (34.8 in.)
Arm (1)	95 mm (3.7 in.)	60 mm (2.4 in.)	900 mm (35.4 in.)
Bucket (1)	85 mm (3.3 in.)	55 mm (2.2 in.)	730 mm (28.7 in.)
Electrical			
Batteries	2 x 12 volt		
Battery Capacity	2 x 450 CCA		
Alternator Rating	60 amp		
Work Lights	2 LED: 1 mounted on boom and 1 mounted on frame		
Undercarriage			
Rollers (each side)			
Carrier	1		
Track	5		
Shoes (each side)	40		
Track			
Adjustment	Hydraulic		
Chain	Sealed and lubricated		
Swing Mechanism			
Swing Speed	10.1 rpm		
Swing Torque	16 600 Nm (12,244 lb.-ft.)		

75 P-TIER EXCAVATOR SPECIFICATIONS

75

P

While general information, pictures, and descriptions are provided, some illustrations and text may include product options and accessories NOT AVAILABLE in all regions, and in some countries products and accessories may require modifications or additions to ensure compliance with the local regulations of those countries.

Ground Pressure	75 P-TIER
450-mm (18 in.) Rubber Crawler Pads	37 kPa (5.4 psi)
600-mm (24 in.) Triple Semi-Grouser Shoes	29 kPa (4.2 psi)

Serviceability

Refill Capacities	
Fuel Tank	125 L (33 gal.)
Cooling System	13.1 L (3.5 gal.)
Engine Oil With Filter	12.3 L (3.2 gal.)
Hydraulic Tank	52 L (14 gal.)
Hydraulic System	100 L (26 gal.)
Propel Gearbox (each)	1.2 L (1.3 qt.)

Operating Weights

With 75-kg (165 lb.) Operator, Oil, Water, Full Fuel Tank, 3.67-m (12 ft. 0 in.) Boom, and 2.12-m (6 ft. 11 in.) Arm	
With 450-mm (18 in.) Track With Rubber Crawler Pad (steel track shoes with vulcanized rubber pads bonded to top of shoes)	8418 kg (18,559 lb.)
With 600-mm (24 in.) Steel Track	8554 kg (18,858 lb.)
With 450-mm (18 in.) Rubber Crawler Pads	8766 kg (19,326 lb.)

Optional Components

Undercarriage (with the following)	
600-mm (24 in.) Triple Semi-Grouser Shoes	3061 kg (6,748 lb.)
450-mm (18 in.) Rubber Crawler Pads	2925 kg (6,449 lb.)
1-Piece Boom (with arm cylinder)	485 kg (1,069 lb.)
2.12-m (6 ft. 11 in.) Arm With Bucket Cylinder and Linkage	282 kg (622 lb.)
Boom Lift Cylinders (2), Total Weight	178 kg (392 lb.)
Counterweight, Standard	1165 kg (2,568 lb.)

Operating Dimensions

Arm Length		2.12 m (6 ft. 11 in.)
Arm Digging Force (ISO)		35.3 kN (7,936 lb.)
Bucket Digging Force (ISO)		59.0 kN (13,264 lb.)
A	Maximum Reach	6.87 m (22 ft. 6 in.)
B	Maximum Digging Depth	4.65 m (15 ft. 3 in.)
C	Maximum Cutting Height	7.58 m (24 ft. 10 in.)
D	Maximum Dumping Height	5.48 m (18 ft. 0 in.)
E	Minimum Swing Radius	2.12 m (6 ft. 11 in.)
F	Tail-Swing Radius	1.39 m (4 ft. 7 in.)

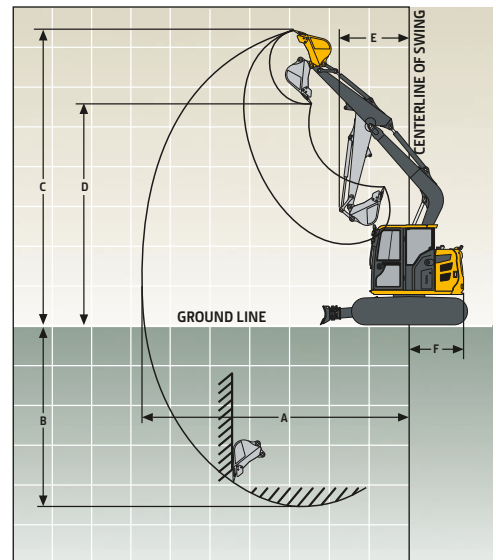

75 P-TIER

While general information, pictures, and descriptions are provided, some illustrations and text may include product options and accessories NOT AVAILABLE in all regions, and in some countries products and accessories may require modifications or additions to ensure compliance with the local regulations of those countries.

Machine Dimensions		75 P-TIER
Arm Length 2.12 m (6 ft. 11 in.)		
A	Overall Length	6.32 m (20 ft. 9 in.)
B	Overall Height in Transport Position	2.73 m (8 ft. 11 in.)
C Undercarriage Width		
	With 450-mm (18 in.) Rubber Crawler Pad	2.20 m (7 ft. 3 in.)
	With 600-mm (24 in.) Steel Track	2.47 m (8 ft. 1 in.)
D	Rear-End Length/Swing Radius	1.39 m (4 ft. 7 in.)
E	Distance Between Idler/Sprocket Centerline	2.30 m (7 ft. 6 in.)
F	Undercarriage Length	2.90 m (9 ft. 6 in.)
G	Counterweight Clearance	0.72 m (28 in.)
H	Cab Height	2.52 m (8 ft. 3 in.)
I	Ground Clearance	360 mm (14 in.)
J	Upperstructure Width	2.35 m (7 ft. 9 in.)
K	Gauge Width	1.75 m (5 ft. 9 in.)
L	Blade Lift Height	370 mm (15 in.)
Blade Height 472 mm (19 in.)		
Blade Width		
	With 450-mm (18 in.) Rubber Crawler Pad	2200 mm (7 ft. 9 in.)
	With 600-mm (24 in.) Steel Track	2200 mm (7 ft. 3 in.)
M	Blade Cut Below Grade	290 mm (11 in.)
N	Blade Lift Angle	27 deg.
O Track Width		
	With 450-mm (18 in.) Rubber Crawler Pad	0.45 m (18 in.)
	With 600-mm (24 in.) Steel Track	0.60 m (24 in.)

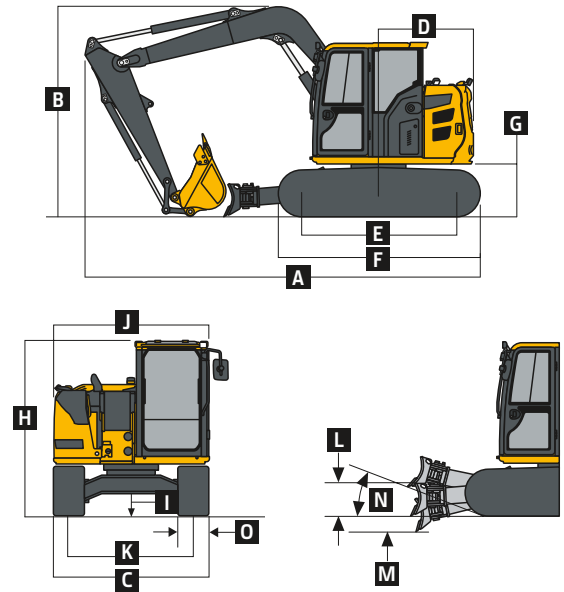

Lift Capacities

Boldface type indicates hydraulically limited capacities; lightface type indicates stability-limited capacities, in kg (lb.). Ratings are at bucket lift hook, using standard counterweight, situated on firm, level, uniform supporting surface. Total load includes weight of cables, hook, etc. Figures do not exceed 87% of hydraulic capacity or 75% of weight needed to tip machine. All lift capacities are based on ISO 10567.

LOAD POINT HEIGHT	HORIZONTAL DISTANCE FROM CENTERLINE OF ROTATION					
	1.5 m (5 ft.)		3.0 m (10 ft.)		4.5 m (15 ft.)	
	Over Front	Over Side	Over Front	Over Side	Over Front	Over Side
<i>With 3.67-m (12 ft. 0 in.) boom, 2.12-m (6 ft. 11 in.) arm, and 450-mm (18 in.) track with rubber crawler pad (steel track shoes with vulcanized rubber pads bonded to top of shoes), with blade on ground, without bucket</i>						
4.5 m (15 ft.)					1559 (3,436)	1559 (3,436)
3.0 m (10 ft.)			1936 (4,269)	1936 (4,269)	1696 (3,738)	1565 (3,451)
1.5 m (5 ft.)			2976 (6,560)	2678 (5,904)	2046 (4,511)	1475 (3,251)
Ground Line			3631 (8,005)	2487 (5,482)	2338 (5,155)	1396 (3,077)
-1.5 m (-5 ft.)	3901 (8,599)	3901 (8,599)	3636 (8,011)	2442 (5,384)	2327 (5,131)	1370 (3,023)
-3.0 m (-10 ft.)	5112 (11,269)	5112 (11,269)	3130 (6,183)	2520 (5,555)		
<i>With 3.67-m (12 ft. 0 in.) boom, 2.12-m (6 ft. 11 in.) arm, and 600-mm (24 in.) triple semi-grouser shoes, with blade on ground, without bucket</i>						
4.5 m (15 ft.)					1559 (3,436)	1559 (3,436)
3.0 m (10 ft.)			1936 (4,269)	1936 (4,269)	1696 (3,738)	1592 (3,509)
1.5 m (5 ft.)			2976 (6,560)	2723 (6,004)	2046 (4,511)	1501 (3,309)
Ground Line			3631 (8,005)	2532 (5,582)	2338 (5,155)	1422 (3,136)
-1.5 m (-5 ft.)	3901 (8,599)	3901 (8,599)	3634 (8,011)	2488 (5,485)	2327 (5,131)	1398 (3,081)
-3.0 m (-10 ft.)	5112 (11,269)	5112 (11,269)	2805 (6,183)	2565 (5,655)		

While general information, pictures, and descriptions are provided, some illustrations and text may include product options and accessories NOT AVAILABLE in all regions, and in some countries products and accessories may require modifications or additions to ensure compliance with the local regulations of those countries.

75 P-TIER

Lift Capacities (continued)

75 P-TIER

Boldface type indicates hydraulically limited capacities; lightface type indicates stability-limited capacities, in kg (lb.). Ratings are at bucket lift hook, using standard counterweight, situated on firm, level, uniform supporting surface. Total load includes weight of cables, hook, etc. Figures do not exceed 87% of hydraulic capacity or 75% of weight needed to tip machine. All lift capacities are based on ISO 10567.

LOAD POINT HEIGHT	HORIZONTAL DISTANCE FROM CENTERLINE OF ROTATION					
	1.5 m (5 ft.)		3.0 m (10 ft.)		4.5 m (15 ft.)	
	Over Front	Over Side	Over Front	Over Side	Over Front	Over Side
<i>With 3.67-m (12 ft. 0 in.) boom, 2.12-m (6 ft. 11 in.) arm, and 450-mm (18 in.) rubber crawler pad (steel track shoes with vulcanized rubber pads bonded to top of shoes), with blade on ground and additional counterweight, without bucket</i>						
4.5 m (15 ft.)					1559 (3,436)	1559 (3,436)
3.0 m (10 ft.)			1936 (4,269)	1936 (4,269)	1696 (3,738)	1696 (3,738)
1.5 m (5 ft.)			2976 (6,560)	2976 (6,560)	2046 (4,511)	1678 (3,699)
Ground Line			3631 (8,005)	2836 (6,253)	2338 (5,155)	1599 (3,526)
-1.5 m (-5 ft.)	3901 (8,599)	3901 (8,599)	3634 (8,011)	2792 (6,155)	2327 (5,131)	1575 (3,472)
-3.0 m (-10 ft.)	5112 (11,269)	5112 (11,269)	2805 (6,183)	2805 (6,183)		
<i>With 3.67-m (12 ft. 0 in.) boom, 2.12-m (6 ft. 11 in.) arm, and 600-mm (24 in.) triple semi-grouser shoes, with blade on ground and additional counterweight, without bucket</i>						
4.5 m (15 ft.)					1559 (3,436)	1559 (3,436)
3.0 m (10 ft.)			1936 (4,269)	1936 (4,269)	1696 (3,738)	1696 (3,738)
1.5 m (5 ft.)			2976 (6,560)	2976 (6,560)	2046 (4,511)	1705 (3,758)
Ground Line			3631 (8,005)	2882 (6,353)	2338 (5,155)	1626 (3,585)
-1.5 m (-5 ft.)	3901 (8,599)	3901 (8,599)	3634 (8,011)	2838 (6,256)	2327 (5,131)	1601 (3,530)
-3.0 m (-10 ft.)	5112 (11,269)	5112 (11,269)	2805 (6,183)	2805 (6,183)		

Buckets

A full line of buckets is offered to meet a wide variety of applications. Replaceable cutting edges are available through John Deere Parts. Optional side cutters add 150 mm (6 in.) to bucket widths.

Type Bucket	Bucket Width		Bucket Capacity		Bucket Weight		Bucket Dig Force (ISO)		Arm Dig Force (ISO)		Bucket Tip Radius		Number of Teeth
	mm	in.	m ³	cu. yd.	kg	lb.	kN	lb.	kN	lb.	mm	in.	
Heavy Duty	610	24	0.24	0.31	268	591	58	13,039	35	7,868	883	34.76	5
	762	30	0.31	0.41	313	691	58	13,039	35	7,868	883	34.76	6
	914	36	0.39	0.51	358	790	58	13,039	35	7,868	883	34.76	7
Ditching	1219	48	0.49	0.64	330	727	69	15,512	37	8,318	907	35.69	0

75 P-TIER

While general information, pictures, and descriptions are provided, some illustrations and text may include product options and accessories NOT AVAILABLE in all regions, and in some countries products and accessories may require modifications or additions to ensure compliance with the local regulations of those countries.

Bucket Selection Guide*

75 P-TIER

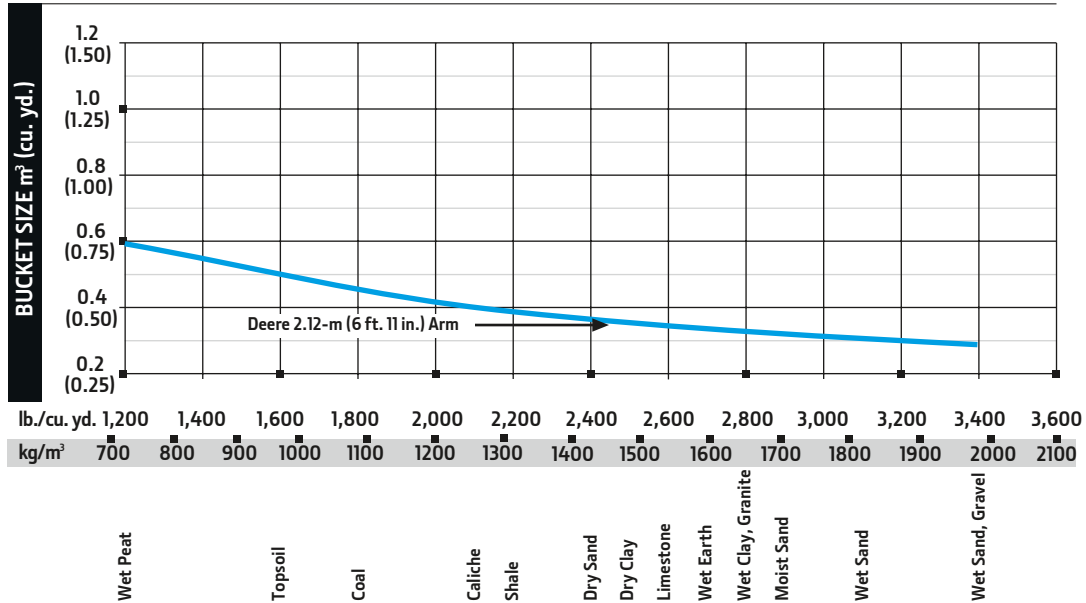

*Contact your John Deere dealer for optimum bucket and attachment selections. These recommendations are for general conditions and average use. Does not include optional equipment such as thumbs or couplers. Larger buckets may be possible when using light materials, for flat and level operations, less compacted materials, and volume loading applications such as mass-excavation applications in ideal conditions. Smaller buckets are recommended for adverse conditions such as off-level applications, rocks, and uneven surfaces. Bucket capacity indicated is SAE heaped.

Additional equipment

Key: ● Standard ▲ Optional or special
See your John Deere dealer for further information.

75 P Engine

- Auto-idle system
- Batteries (2 – 12 volt)
- Coolant recovery tank
- Single-element air filter
- Electronic engine control
- Enclosed fan guard (conforms to SAE J1308)
- Engine coolant to –37 deg. C (–34 deg. F)
- Fuel filter with water separator
- Full-flow oil filter
- Radiator and oil cooler with dust-protective net
- Glow-plug start aid
- 500-hour engine oil-change interval
- 70% (35 deg.) off-level capacity
- Isolation mounted

Hydraulic System

- Reduced-drift valve for boom down, arm in
- Auxiliary hydraulic valve section
- Spring-applied, hydraulically released automatic swing brake
- 5,000-hour hydraulic oil-change interval
- Auxiliary hydraulics with selector valve
- Control pattern-change valve
- ▲ Hydraulic filter restriction indicator kit

Undercarriage

- Planetary drive with axial piston motors
- Propel motor shields
- Spring-applied, hydraulically released automatic propel brake
- 2-speed propel with automatic shift
- Upper carrier roller (1)
- Sealed and lubricated track chain
- Undercarriage with blade
- ▲ Triple semi-grouser shoes, 600 mm (24 in.)
- ▲ Rubber crawler pads, 450 mm (18 in.)
- 2-way backfill blade
- ▲ 4-way angle blade with float

75 P Upperstructure

- Counterweight, 1165 kg (2,568 lb.)
- Right- and left-hand mirrors
- Vandal locks with ignition key: Cab door / Engine hood / Fuel cap / Service doors
- Remote-mounted fuel filters

Front Attachments*

- Centralized lubrication system
- Dirt seals on all bucket pins
- Oil-impregnated bushings
- Reinforced resin thrust plates
- Tungsten carbide thermal coating on arm-to-bucket joint
- Arm, 2.12 m (6 ft. 11 in.)
- ▲ Attachment quick-couplers
- ▲ Buckets: Ditching / Heavy duty / Heavy-duty high capacity / Side cutters and teeth
- Thumb bracket
- Attachment modes and adjustment in main monitor

Operator's Station

- Meets ISO 12117-2 for ROPS
- Adjustable independent control positions (seat-to-pedals)
- AM/FM radio
- Auto climate control/air conditioner with heater and pressurizer
- Built-in operator's manual storage compartment and manual
- Cell-phone power outlet, 12 volt, 60 watt, 5 amp
- Coat hook
- Deluxe cloth, heated, air-suspension seat with adjustable armrests
- Floor mat
- Front windshield wiper with intermittent speeds
- Gauges (illuminated): Engine coolant / Fuel
- Horn, electric
- Hour meter, electric
- Cell-phone holder, USB port, and Bluetooth® calling and audio
- Hydraulic shutoff lever, all controls

75 P Operator's Station (continued)

- Hydraulic warm-up control
 - Interior light
 - Large cup holder
 - Machine Information Center (MIC)
 - Mode selectors (illuminated): Power modes (2) / Travel modes (2 with automatic shift) / Work mode (1)
 - Multifunction, color LCD monitor with: Diagnostic capability / Multiple-language capabilities / Maintenance tracking / Clock / System monitoring with alarm features: Auto-idle indicator, engine air cleaner restriction indicator light, engine check, engine coolant temperature indicator light with audible alarm, engine oil pressure indicator light with audible alarm, low-alternator-charge indicator light, low-fuel indicator light, fault-code alert indicator, fuel-rate display, wiper-mode indicator, work-lights-on indicator, and work-mode indicator
 - Motion alarm with cancel switch (conforms to SAE J994)
 - Auxiliary hydraulic control switches in right console lever
 - SAE 2-lever control pattern
 - Seat belt, 51 mm (2 in.), retractable
 - Tinted glass
 - Transparent tinted overhead hatch
 - Hot/cold beverage compartment
 - ▲ Seat belt, 76 mm (3 in.), non-retractable
 - ▲ Protection screens for cab front, rear, and side
 - ▲ Window vandal-protection covers
- ### Electrical
- 50-amp alternator
 - Blade-type multi-fused circuits
 - Positive-terminal battery covers
 - Right rear left 270-deg. camera system with LED surround lighting
- ### Lights
- Work lights: LED / 1 mounted on boom / 1 mounted on frame

While general information, pictures, and descriptions are provided, some illustrations and text may include product options and accessories NOT AVAILABLE in all regions, and in some countries products and accessories may require modifications or additions to ensure compliance with the local regulations of those countries.

Net engine power is with standard equipment including air cleaner, exhaust system, alternator, and cooling fan at test conditions specified per ISO 9249. No derating is required up to 3050-m (10,000 ft.) altitude. Specifications and design subject to change without notice. Wherever applicable, specifications are in accordance with SAE standards. Except where otherwise noted, these specifications are based on a unit with standard equipment; 0.28-m³ (0.37 cu. yd.), 750-mm (30 in.), 211-kg (465 lb.) bucket; 2.12-m (6 ft. 11 in.) arm; 1165-kg (2,568 lb.) counterweight; full fuel tank; and 75-kg (165 lb.) operator.



ME75PAU (23-08)



JOHN DEERE